

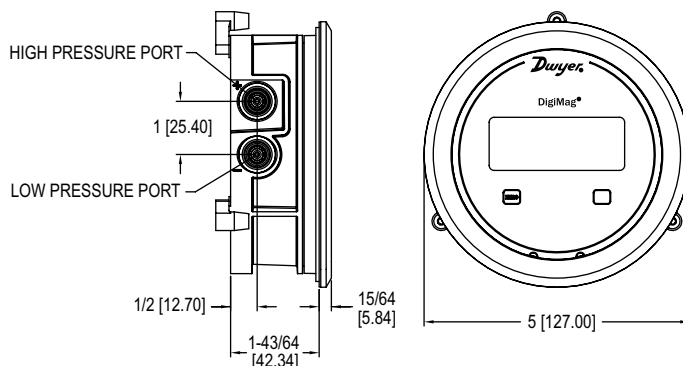

Series DM DigiMag® Differential Pressure Transmitter

Specifications - Installation and Operating Instructions



The **Series DM DigiMag® Differential Pressure Transmitter** senses the pressure of air and compatible gases and sends a standard 4-20 mA output signal. The DM housing is specifically designed to mount in the same diameter cutout as a standard Magnehelic® gage. A wide range of models are available factory calibrated to specific ranges. The polycarbonate molded housing features integral pressure connections, which reduces installation time. Digital push-button zero and span simplify calibration over typical turn-potentiometers. A single push-button allows field selection of 4 to 6 engineering units, depending on the range.

BENEFITS/FEATURES

- Reduced installation time through zero and span controls that provides quick and easy calibration
- Fast and easy setup and calibration with push-button zero and span controls
- Immediate corrective action can be taken by local alerts via the easy-to-read LCD display
- Reduces upgrade installation costs and simplifies field upgrade from a Magnehelic® gage, as both use the same diameter cutout

APPLICATIONS

- Differential pressure across filters
- Fan control
- Static pressures in ducts or buildings
- Room pressurization monitoring

INSTALLATION

Location:

Select a clean, dry mounting location free from excess vibration where the temperature will remain between -4 to 158°F (-20 to 70°C). Distance from the receiver is limited only by total loop resistance. See Electrical Connections on the next page. The tubing supplying pressure to the instrument can be practically any length required, but long lengths will increase the response time slightly.

Position:

Transmitter pressure accuracy is not affected by orientation. If choosing a non-vertical installation, ZERO the unit to remove any offset due to gravity.

Pressure Connections:

NOTICE

Two integral tubing connections are provided on the side of the gage. They are sized to fit 1/8", 3/16", 1/4", 5 mm, and 6 mm ID flexible tubing. Be sure the pressure rating of the tubing exceeds that of the operating ranges.

SPECIFICATIONS

Service: Air and non-combustible, compatible gases.

Wetted Materials: Consult factory.

Housing Material: Polycarbonate.

Accuracy: ±1% FSO for all ranges except 0.25 in w.c. @ ±2% FSO, and ranges at or below ±0.1 in w.c. @ ±4% FSO.

Stability: < ±1% / year FSO.

Pressure Limits: Ranges > 1 in w.c.: 6 psi max operation, 6 psi burst; Ranges ≤ 1 in w.c.: 3.6 psi max operation, 6 psi burst.

Temperature Limits: -4 to 158°F (-20 to 70°C).

Thermal Effect: 0.036% FS/°C (0.02% FS/°F).

Power Requirements: 10-35 VDC (2-wire).

Output Signal: 4-20 mA (2-wire).

Zero and Span Adjustments: Push-button.

Loop Resistance: 0 to 1250 Ω max.

Current Consumption: 21 mA max.

Electrical Connections: Screw-type terminals.

Process Connections: Male ports on side for 1/8", 3/16", 1/4", 5 mm, 6 mm ID flexible tubing.

Enclosure Rating: NEMA 4X (IP66).

Mounting Orientation: Not sensitive to position.

Size: 5" OD (127 mm) x 1.9" (48 mm) deep.

Weight: 7.04 oz (200 g).

Compliance: CE.

MOUNTING

Panel Mount:

Provide a 4-9/16" diameter opening in panel. Insert gage and secure in place with provided screws and mounting lugs.

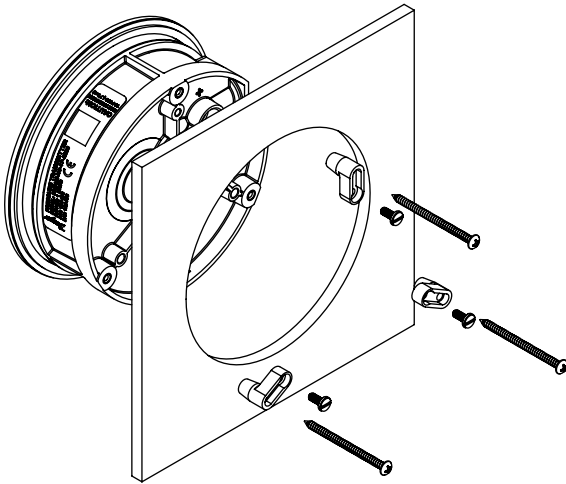

Figure 1: Panel mount

Surface Mount:

Provide three 3/16" diameter holes in panel on a 4-1/8" diameter bolt circle. Cut an opening for the terminal block as shown in Figure 2.

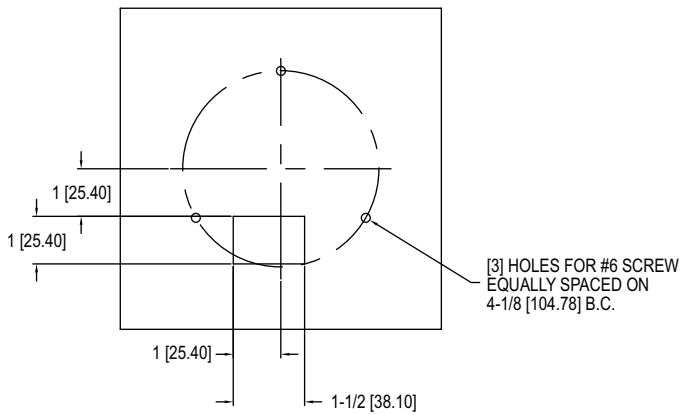

Figure 2: Surface mount

ELECTRICAL CONNECTIONS

CAUTION Do not exceed specified supply voltage ratings, as doing so will result in permanent damage not covered by warranty. This unit is not designed for 120 or 240 V AC line operation.

Electrical connections are made to the terminal block located in the back of the transmitter. Terminals are marked + and COM (see Figure 3 below).

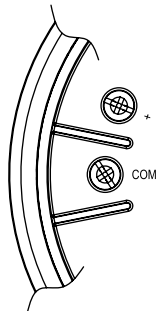

Figure 3

Wire Length

The maximum wire length connecting the transmitter to the receiver depends on the on the wire gage and the resistance of the receiver. When calculating loop resistance, wiring should not contribute more than 10% of the receiver resistance. For runs over 1000', choose a receiver with greater resistance. When wiring length is less than 100', 22 AWG wire can be used.

2-Wire Operation

An external power supply delivering 10-35 VDC with minimum current capability of 40 mA DC (per transmitter) must be used to power the control loop. See Figure 4 for connection of the power supply, transmitter, and receiver. The range of appropriate receiver load resistance (RL) for the DC power supply voltage available is expressed by the formula and graph in Figure 5. Shielded two wire cable is recommended for control loop wiring. If grounding is required, use the negative side of the control loop after the receiver.

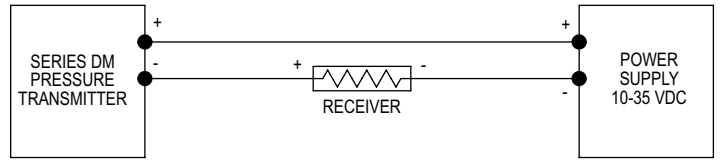

Figure 4

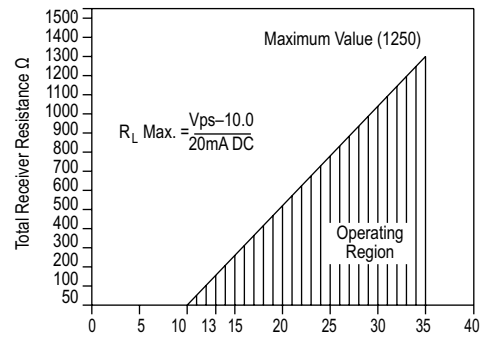

Figure 5

SELECT UNIT OF MEASUREMENT

To select a unit of measurement, press and release the UNITS button to cycle through the available options. The LCD will display the current selected unit.

CALIBRATION

To calibrate the transmitter you will need three pieces of equipment:

1. A calibrated pressure source capable of generating a stable pressure value for the maximum range of the unit under test
2. An instrument capable of validating the calibration pressure
3. An ammeter capable of measuring the current mA output from the unit under test

The transmitter is calibrated using the following procedure.

Preparing for Zero Calibration, Span Calibration, Response Time Calibration, or Restore Factory Calibration Coefficients

To prepare the unit for zero or span calibration, response time calibration, or to restore factory calibration coefficients, start by preparing the unit as instructed below:

1. Connect the ammeter and power supply, being careful to observe polarities.
2. Press both the ZERO and UNITS buttons simultaneously for 6 or more seconds, or until "CAL" is displayed. Release both buttons.
3. The units indicator on the LCD should blink on and off. This indicates the gage is ready for calibration or restoration of coefficients. The unit's indicator will blink for approximately 10 minutes, then stop blinking.

Zero Calibration

- Apply zero pressure to both ports.
- Press the zero button for 3 seconds. Release.
- The zero function will be processed 3 seconds after the button is released.
- The display will read "2Er" and then sequence back to the home display.

Span Calibration

NOTICE

For a positive span, apply pressure to the positive "+" port.

The span calibration function allows the pressure value to be adjusted so that the currently applied pressure is the maximum configured pressure. This will in turn set the maximum analog output at the set pressure. It is recommended that the ZERO function be applied before performing a span calibration.

- Apply the maximum desired pressure to the device.
- Press and hold the UNITS button for 3 seconds.
- The span function will be processed 3 seconds after the span button is released.
- The display will read "SPA" and then sequence back to the home display.

Response Time Calibration

Press both the "ZERO" and "UNITS" buttons simultaneously for 3 seconds to toggle between fast (0 seconds) and dampened (4 seconds) response. The display will read FST or SLO to indicate which mode is now selected.

Restore Factory Calibration

To restore the gage's factory calibration coefficient:

- Press both the "ZERO" and "UNITS" buttons simultaneously for 6 seconds or until "rSt" is displayed.
- The device will reboot after 5 or 6 seconds.

MAINTENANCE

Upon final installation of the Series DM, no routine maintenance is required. The Series DM is not field serviceable and should be returned if repair is needed. Field repair should not be attempted and may void warranty.



This symbol indicates waste electrical products should not be disposed of with household waste. Please recycle where facilities exist. Check with your Local Authority or retailer for recycling advice.

WARRANTY/RETURN

Refer to "Terms and Conditions of Sale" in our catalog and on our website. Contact customer service to receive a Return Materials Authorization (RMA) number before shipping the product back for repair. Be sure to include a brief description of the problem plus any additional application notes.

MODEL CHART						
Model	Range					
	in w.c.	Pa	mm w.c.	mBar	kPa	psi
DM-001	0 to .100	24.9	2.54	0.249	-	-
DM-002	0 to .250	62.2	6.35	0.622	-	-
DM-003	0 to .500	124.3	12.7	1.243	0.124	-
DM-004	0 to 1.000	249	25.4	2.49	0.249	-
DM-005	0 to 2.00	497	50.8	4.97	0.497	-
DM-007	0 to 3.00	746	76.2	7.46	0.746	0.108
DM-008	0 to 5.00	1243	127.0	12.43	1.243	0.18
DM-019	-0.05-0-0.20	-12.45 to 49.81	-1.269 to 5.079	-0.12 to 0.49	-	-
DM-201	±0.1 in w.c.	-24.9 to 24.9	-2.53 to 2.53	-0.249 to 0.249	-	-
DM-202	0 to ±.250	0 to ±62.2	0 to ±6.35	0 to ±.622	-	-
DM-203	0 to ±.500	0 to ±124.3	0 to ±12.70	0 to ±1.243	-	-
DM-052	0 to .120	30	3.05	0.3	-	-
DM-053	0 to .240	60	6.11	0.6	-	-
DM-056	0 to 1	250	25.49	2.5	0.25	-
DM-059	0 to 5	1250	127.46	12.5	1.25	0.18
DM-252	-0.120 to 0.120	±30	-3.05 to 3.05	-0.3 to 0.3	-	-
DM-253	-0.240 to 0.240	±60	-6.11 to 6.11	-0.6 to 0.6	-	-
DM-256	-1 to 1	±250	-25.49 to 25.49	-2.5 to 2.5	-0.25 to 0.25	-
DM-259	-5 to 5	±1250	-127.46 to 127.46	-12.50 to 12.50	-1.25 to 1.25	-0.18 to 0.18
DM-082	0 to 0.23	58.83	6	0.58	-	-
DM-282	-0.23 to 0.23	-58.83 to 58.83	±6	-0.58 to 0.58	-	-

