

207-SM Control Panel Instruction 12VDC and 24VDC For Swing Gates

General safety rules

WARNING: Unskilled personnel should never be allowed to assemble, repair or adjust the devices and all necessary precautions must be taken to prevent accidents: power supply disconnected (including backup batteries if present). This product is not suitable for installation in explosive atmospheres.

Keep this handbook carefully, store it attached to the technical installation leaflet in a safe place where it is available to anyone who may need it and make sure that all involved personnel are aware of this.

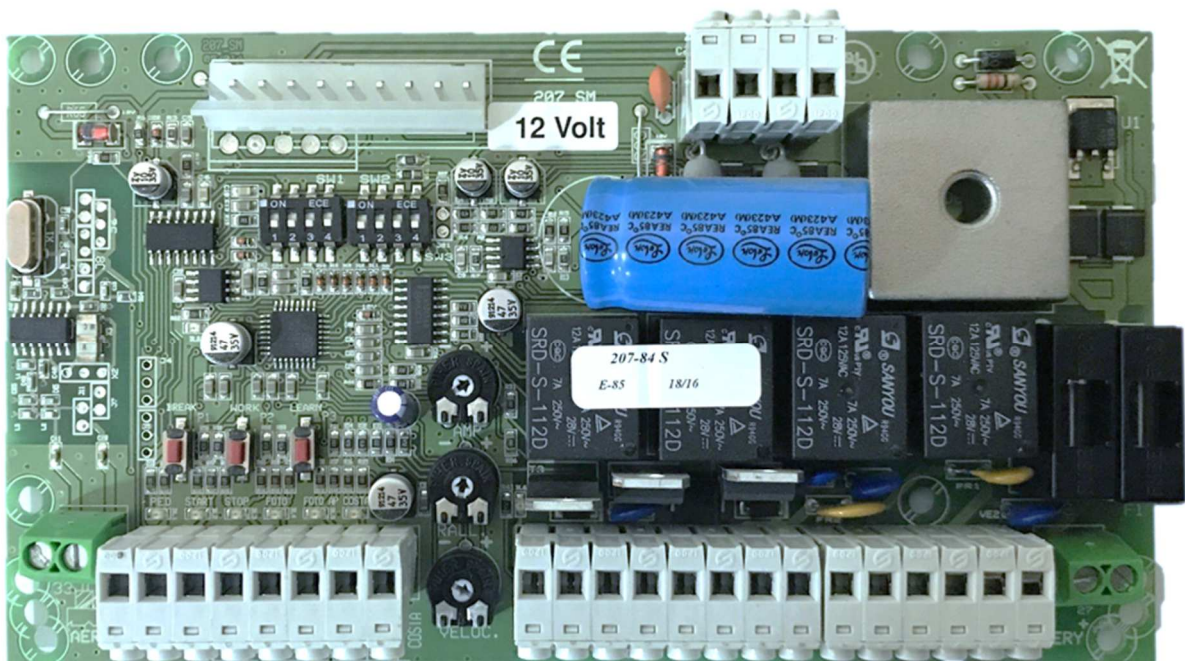

Type of product

The 207 control panel has been designed to control 1 or 2 operators 12VDC and a 24VDC version for swing gates. It has an on-board integrated radio receiver. It is also possible to set the slowing down and anti-crushing features that grant an easy and safe installation, free from interference and protected against atmospheric and electrostatic discharges. The control board 207 has succeeded all tests concerning the electromagnetic emissions and the immunity to the interference as provided by the European rules in force. It conforms to the directives EMC 89/336/CEE, 92/31/CEE, BT 73/23/CEE and 93/68/CEE

Contents

Page

- 3) DESCRIPTION OF THE MAIN COMPONENTS. Obstacle detection system, battery charging, dip switch Programmable Functions, Terminal legend and general PCB schematic.
- 4) Terminal Descriptions
- 5) Trimmers and Dip Switch
- 6) Fuses
- 7) Wiring the 207 controller
- 8) About Photocells
- 9) Wiring the photocells
- 10) Programming the 207C circuit board
- 11) Automatic programming of working times and slowing speed
- 12&13) Manual programming of working times and slowing speed
- 14) Programming automation closing
- 15&16) Wireless Keypad Programming
- 17) UNAC safety guide

If any welding takes place during your build, it is essential that any cabling is isolated totally from the control panel.



It is also best practice to use the correct suitable cable glands and conduit from only the bottom of the enclosure along with silicone of any gaps to avoid any insect infestation.



Obstacle detection system

The 207 board is equipped with obstacle detection and the sensitivity can be adjusted by using the trimmer marked **AMP**. The working speed can be adjusted using the trimmer marked **VELOC** and the slowing down speed using the trimmer marked **RALL**.

When the system is in operation and the gate meets an obstacle during the opening cycle, it will reverse the stroke for about 5 centimetres and it will then auto re-close after 30 seconds. If the automatic closing is set, it will follow the set time before closing again. If the gate is at the deceleration stage (usually around 500mm before fully open or close) it will stop and not move again until given another command. If the gate meets an obstacle while closing, it will reverse completely and it will auto re-close after 30 seconds. If the automatic closing is set, it will follow the set time. If it is at the deceleration stage, it will stop and not move again until given another command.

Full obstacle detection control throughout the full cycle of opening and closing (including the slowdown stage) can be achieved by using a safety edge, (Rib edge) through the '**COSTA**' input on J1 terminal 8. The wired safety edge system can be used with normally closed circuits and resistor 8k2 ohm circuits. Safety edges are used on gates in all areas where a specific risk of trapping may occur, especially where there is less than a 50cm gap behind a gate when fully open. Resistor 8k2 ohm circuits are used where CAT3 safety edges are needed. The 8k2 ohm circuit when installed correctly will always fail to safe if damaged shorted or open circuited.

Battery charging

The board is able to work with or without a battery. If the system is operating with a battery, the board itself will recharge the battery. About 24 hours are required to completely recharge the battery. The board draws, with a 7 Ah battery, in the normal working 140 mA equal to 50 hours and in stand-by 38 mA equal to 84 hours.

1 Safety advises.

In order to prevent any kind of accident, only qualified and professional people will be allowed to operate, install, repair or adjust the control panel and only after all the necessary safety rules have been respected, as well as power supply cut off (including the back up batteries). If the control panel will be used for any other purpose (not reported in the user manual), will be not responsible for any kind of damage or accident caused to people, animals or things. This product is not suitable to be installed in an explosive atmosphere. Keep this booklet together with the rest of the technical information regarding the installation in a suitable place and available to professional installer who will need to do future maintenance.

2 Description of the terminals and wiring.

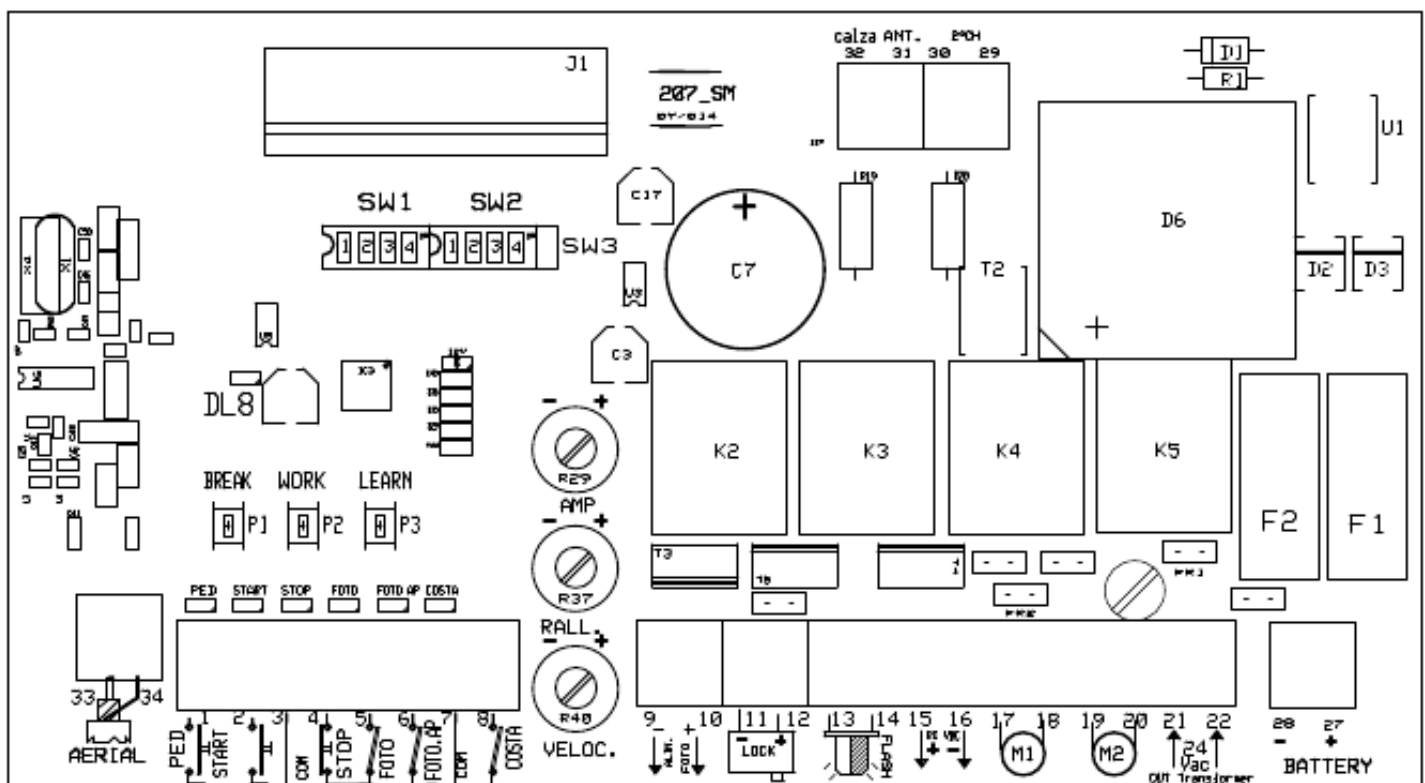

Terminal	Description
1-3	Input Pedestrian (N.O. contact); It opens only the leaf of M1.
2-3	Input Start (N.O. contact); step by step feature (open-stop-close).
3-4	Input Stop (N.C. contact) it always stops the motors. If the contact is used during the pause, it cancels the automatic shutting.
5-7	Input photocells (N.C. contact) working only when gate is closing (it stops and re-opens).
6-7	Input photocells working when gates is opening/closing (N.C. contact). While opening the gate stops and then re-start; while closing the gate stops and reverses.
7-8	Input safety edge (N.C. contact) working both in opening/closing. While opening it stops and reverses for 10cm. While closing it stops and reverses completely.
9-10	Output 24 VDC for photocells power supply (9 negative, 10 positive).
11-12	Output 24 VDC- Dip 2 SW2 OFF Electro-lock - Dip 2 SW2 ON Indicator of gate movement (11 negative, 12 positive).
13-14	Output 24 VDCfor the flashing light (13 negative, 14 positive).
15-16	Output 24 VDC for accessories (15 positive, 16 negative).
17-18	Output 24Vdc for Motor 1 (max 3A).
19-20	Output 24Vdc for Motor 2 (max 3A).
21-22	Control panel power supply 24 VAC. Wire it to the 24VAC output of the toroidal transformer.
23-24	Input main power supply 230 VAC.
25-26	Main transformer (toroidal 230VAC).
27-28	Back up battery input (27 positive, 28 negative).
33-34	Input antenna for onboard receiver (33 coaxial wire, 34 shield).
SW3	Jumper to get an additional feature in terms of powerful; with jumper, more power - without jumper, less power.

P.S.: This control panel is delivered with all N.C. outputs wired (stop, safety edge, photocells, photocells open). If you want to use one of those outputs, cut the wire and do the connection accordingly.

3 LED description.

PED	It shows the output Pedestrian (normally switched off).
START	It shows the output START (normally switched off).
STOP	It shows the output STOP (normally switched on).
FOTO	It shows the output FOTO (normally switched on, and if the photocells is engaged it switched off).

FOTO	It shows the output FOTO.AP (normally switched on, and if the photocells is engaged it switched off).
COSTA	It shows the output safety edge (normally switched on, and if the safety edge is engaged it switched off).
DL6	It shows the state of the setting.

Close the gate and check that LED stop, FOTO, FOTO. AP and COSTA are switched on; otherwise re-check the wiring.

4 Trimmer description.

AMP	Anti-crushing (obstacle detection) adjustment, when the gate is moving. Moving more to the (-) = high sensitivity. A small obstacle detected, adjusted according to the local norms of safety.
RALL.	Controls the speed during the slow part of the opening and closing. IE. just before fully open and closed. Moving more to the (-) = slower. Moving more to the (-) = faster during this part.
VELOC.	This parameter controls the overall main speed of the gate and it should be adjusted according to the local norms of safety. Moving more to the (-) = slower. Moving more to the (-) = faster.

5 Dip Switches SW1 & SW2 features.

S W 1	ON	OFF
1	Working only with 1 motor. Use input M1.	Working with 2 motors (M1 + M2).
2	Feature “close immediately” enable. When the gate is opening, as soon as the photocells are disengaged, the gate closes after 5 seconds.	Feature “close immediately” disable.
3	First push in an opposite way to release the electro-lock (for gates with electro-lock only).	Push disable.
4	Extra push while starting disable.	Extra push of 2 seconds while starting.
S W 2	ON	OFF
1	Residential feature enable (while opening the control panel does not accept any other Start impulse). When gate has opened, a Start impulse closes the gate without considering the automatic shutting set on it. Residential feature disable. Step by step feature enable also during opening.	Residential feature disable. Step by step feature enable also during opening.
2	Enable the indicator of gate movement/position on inputs 10-11 (LOCK).	Enable electro-lock on inputs 10-11 (LOCK).
3	Enable use of resistive safety edge of 8K2.	Enable use of mechanical safety edge (N.C. Contact)

4	Release	Release off
---	---------	-------------

6 Fuses description.

F1 - 20A 250V Output battery protection fuse (27 - 28).

F2 - 20A 250V Transformer output 24VAC protection fuse.

FR1 - 0,5A 250VMain power supply 230VAC self-repairing protection fuse (**non-replaceable**).

FR2 - 1,6A 250VSelf-repairing protection fuse for photocells, electro-lock, flashing light and accessories (**non-replaceable**).

WARNING: High risk of electric shock! Cut off the main power supply from the panel before touching the fuses (F1 and F2).

We recommend to re-check the wiring before replacing any fuse

7 Remote control storing (recommended to be done with the antenna disconnected).

As **START** button:

1) Close the gate. Press once the button **PROGR**; led **DL6** starts flashing.

2) Press the remote control button you want to store; led **DL6** switched off as confirmation that code has been stored.

You can store up to max. 32 different codes for the Start.

As **Pedestrian** button:

1) Close the gate. Press twice the button **PROGR**; led **DL6** starts flashing.

2) Press the remote control button you want to store; led **DL6** switched off as confirmation that code has been stored.

You can store up to max. 32 different codes for the Pedestrian.

8 Remote control cancellation.

Cancellation of a single code stored into START or PEDESTRIAN:

1) Press at the same time both buttons **PROGR** and **PAUSA**; led **DL6** starts flashing quickly.

2) Within 10 sec. press remote control button you want to cancel; led **DL6** switches off to confirm the cancellation.

Cancellation of all codes stored into the control panel:

Press at the same time both buttons **PROGR** and **PAUSA** for about 10 seconds.

Led **DL6** starts flashing quickly and after 10 seconds will switch off confirming the cancellation has been done.

9 Preliminary checks before setting the control panel.

1) Power the control panel and verify that LED Stop, Foto, Foto AP and Costa are on; if this doesn't correspond, re-check the wirings and or safety devices state. Any NC contact not used, has to be wired/closed.

2) Verify that all safety devices installed in the gate are working properly in order to reduce any possible accident.

3) Verify the correct wirings, keeping in mind that 1st START impulse has to open the gate, otherwise, just swap the wires 17-18 for M1 and/or 19-20 for M2.

Wiring the 207 controller. Step 1

Cable Information

Main Supply 230Vac @ 3.0Amp (minimum)

Photocells, Safety Edges and Viro Lock -BT cable,
CW1128 with conduit recommended.

Motors 2 Core 1.5mm² MIN.

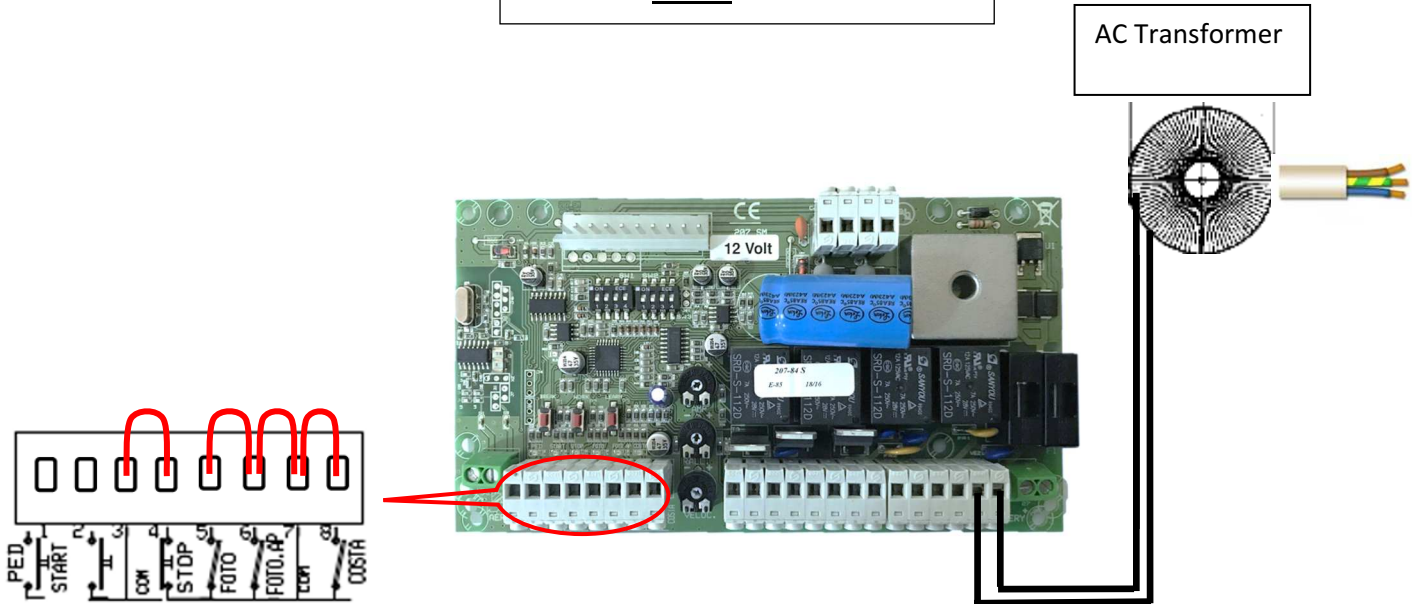

Wiring the 207 controller. Step 2

With single motor, SW1-1 needs to be on (up). With double motor SW1-1 is down. At this stage, all other DIPs off.

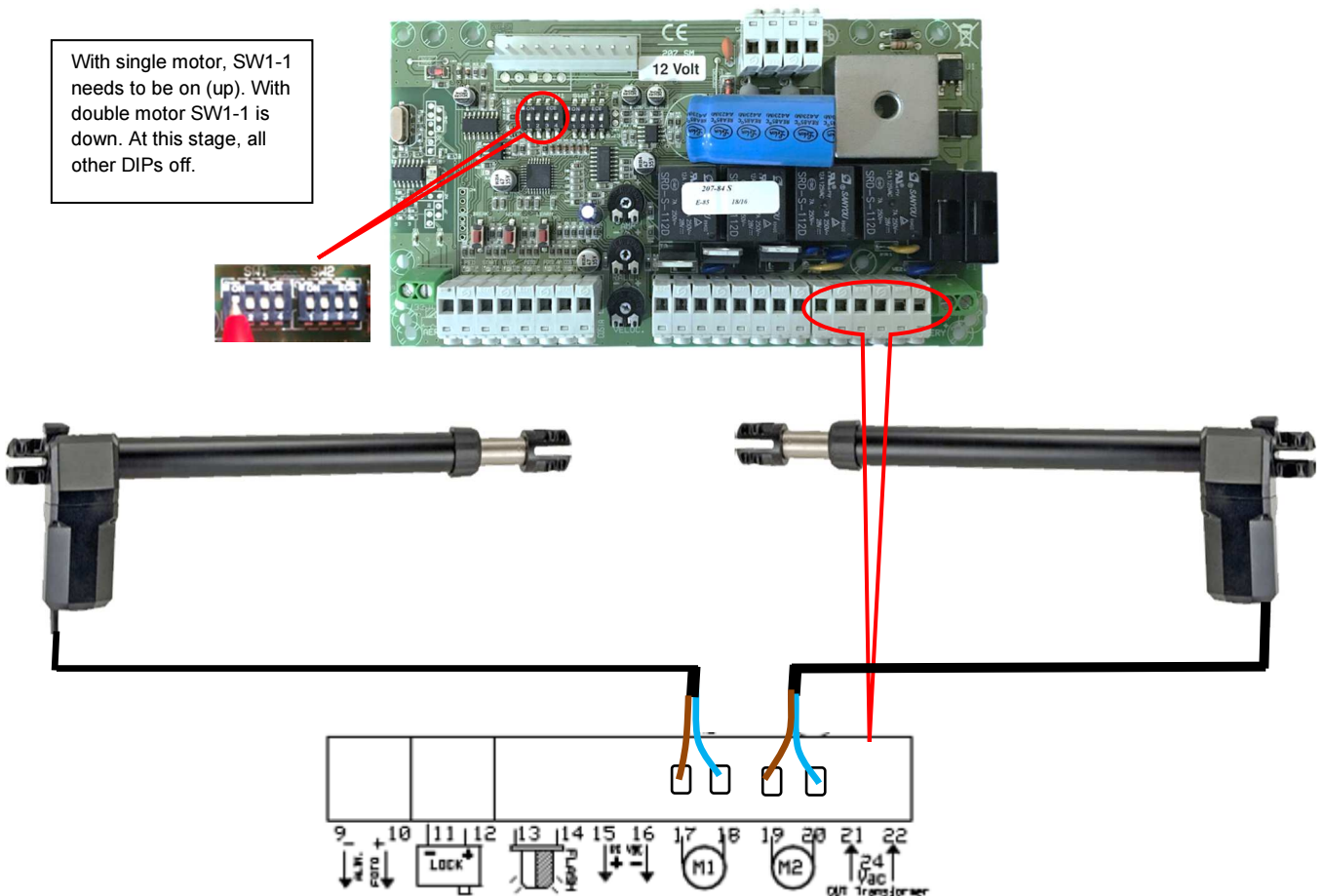

Photocells

The photocells are in pairs, one transmitter and one receiver. They should be mounted 500-600 mm from the ground and face each other level. Each photocell regardless of type has a 12-volt or 24-volt positive and negative supply. (Please see Technical Specification for 12v or 24v Control unit)

The receiving photocell does the switching on and off to the control panel. If the transmitting beam can reach the receiving photocell, there will be a completed circuit to the main panel and the gate/s will function. If the beam is broken, during operation of closing, the gates will stop and reopen. If the beam is broken before the motors have started, the gate will not function.

If you are using two pairs of photocells as pictured, the receivers should be crossed on opposite sides so that you do not have two receivers at the same side.

For this purpose 4 core BT type cable is recommended for use, (CW1128) Follow the wiring diagram provided to wire both the receiver and transmitting photocells. At the control box end, wire the colour coded cables up as per the diagram provided showing a typical photocell placement.

When the photocells are working and correctly aligned, you should hear a clicking sound from the transmitter when the beam is broken intermittently. Once wired, place the covers over the photocells and secure the fixing screw. Fill any cable gaps with silicone to prevent insects from entering the device and interfering with it.

Surface Mounted Photocells

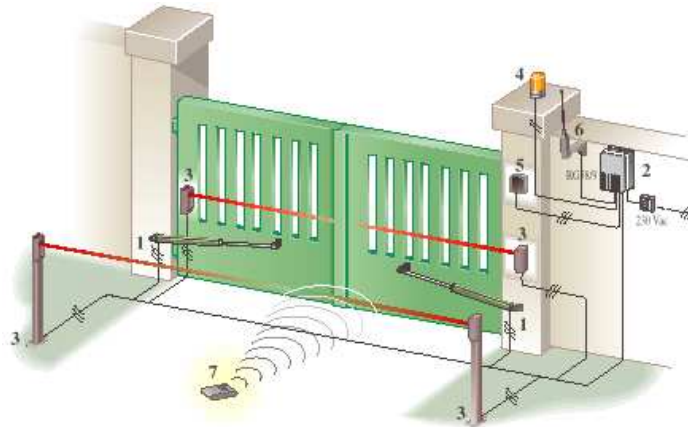

Wiring Step 3.

Adding the photocells

Please note, it is possible to skip this step and proceed straight to programming, but you must add the photocells later before finally commissioning to work.

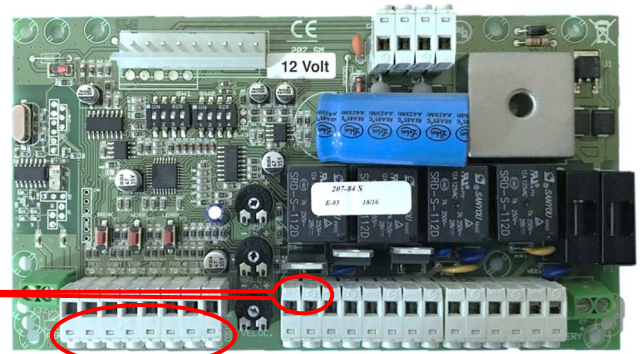

One pair wiring FES-180, BIG/1/F Photocell.

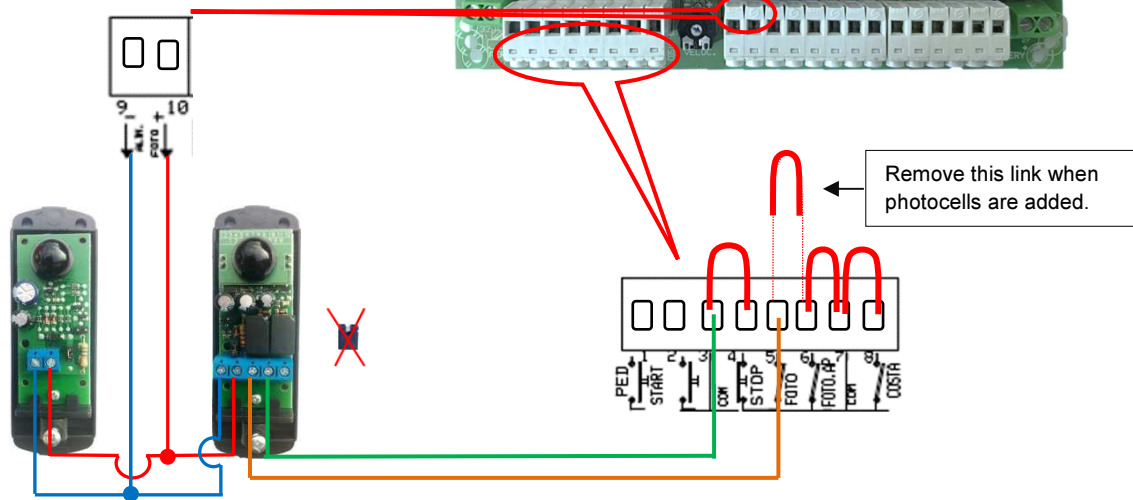

Two pair wiring FES-180, BIG/1/F Photocell.

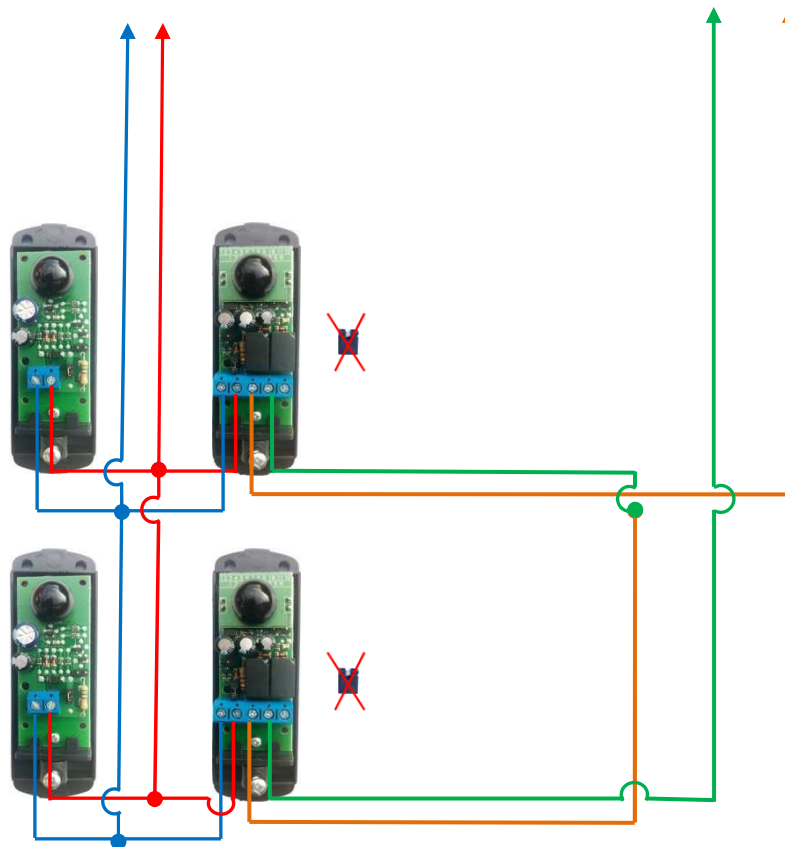

The vertical jumpers should **not** be installed as the 909 photocell power is 24VAC. Install all the anti rotation screws once the photocells are aligned correctly.

CROSS REFERENCE WITH YOUR PHOTOCELL IF NOT FES-180 or BIG/1/F Photocell.

Programming the 207C circuit board

Before you start to programme!

Check that the gate wing stops are in place and set!

Check that you have wired the photocells correctly and bridged (linked) the normally closed (N.C) circuits that are not being used. If you have done this correctly, you should have these LEDs illuminated with the power to the circuit board on.

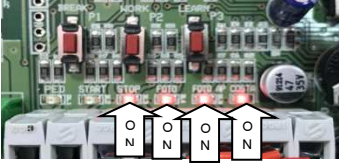

The first two LEDs from the left should only appear when an open command or a pedestrian command is given. If the fourth from the left LED is missing check your photocell wiring circuit and alignment of the beams. If any other LEDs marked ON are not illuminated, check the circuits or the links outlined on the typical wiring diagram page.

STEP1 Programming the remotes

Note Carry out programming the remotes only with the aerial disconnected from the PCB. This avoids picking up stray frequency codes from other equipment. Reconnect only when you have finished programming the remote control equipment.



STEP1 with KW113 remote,

open the cover and randomly arrange the dip-switches first.



STEP1 with A3a-V2 and I8 remotes,

Carry out the How to generate a random code procedure.

WITH JANE REMOTES GO STRAIGHT TO STEP 2

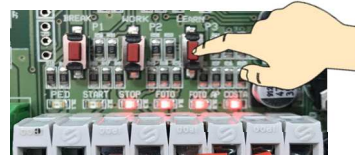

STEP2

Enter radio code programming (for the START control). Press and release the **LEARN.** button once, the LED DL6 will start to flash. . **Go to STEP3.** The board accepts the code and exits from programming (DL6 turns off). It is possible to store up to a maximum of 32 different codes for the START control.



STEP3.

While the DL6 is flashing, press and hold the button on your remote you want to open the gate fully for 3 seconds.

STEP4 Verify motor direction

You need to verify that the motors are going in the right direction in relation to the panel. Arrange gate's so that they are both approximately half way. Turn the power off to the panel. **(It is important that you leave the power off to the panel at least 15 seconds or the fuse may fail when you turn back on the power)** Turn the power back on again. Press once the key fob that you previously learned in at step 2 and 3. Observe the direction that both gates move in at the start and then immediately turn the power off again. The gate if that travels in an open direction is correct. The gate that travels in a closing direction is incorrect. Identify this motor at the PCB as M1 or M2 and these motor wires need swapping with each other.



How to generate a random fob code for A3a-V2 and I8 Remotes

Press and hold button (1)

Keep button (1) pressed then press and hold button (2) (The led flashes slower)

Keep both buttons pressed for 15 seconds (The led will start to flash faster).

Whilst still holding in buttons (1) & (2), Release button (1) wait 2 seconds and release button (2).

You have now generated a random code in both buttons.

This code can now be learned to the radio receiver card.

STEP5 Automatic programming of working times and slowing speed

Make sure that you have end stops for each wing set. Depending on the motor type, these may be built into the motor or for motors without stops a gate wing stop will be needed. A closing floor stop, (CENTRE STOP) is highly recommended in any case because this ensures that the gates are held tight when closed. The gates will not programme or run without any stops, it needs them to figure out its positions.

AUTOMATIC-PROGRAMMING

The following describes the automatic-programming stages for the two gates; in the event of single gate, **M1** (DIP1 SW1 = ON), only the stages relating to motor **M1** are carried out.



- 1) Position the gate/s at fully open and make sure the motors are locked into drive. You can check this by pulling or pushing the gate slightly, if the motor was previously un-locked, the motor will click and the gate wing will lock.
- 2) Arrange the trimmers to an initial setting point. With 24V motors, set the AMP and RALL trimmers to 11 O'clock. With 12V motors, set the AMP and RALL trimmers to 12 O'clock. Set the VELOC trimmer to full.

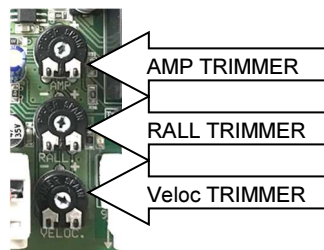

- 3) With the gates open, turn the power off to the panel. Then at least 15 seconds later, turn the panel back on again (**It is important that you leave the power off to the panel at least 15 seconds or the fuse may fail when you turn back on.**)
- 4) Press and hold on P3, (LEARN) DL6 will start to flash, about 15 seconds later DL6 will flash much faster and one click will emit from the board. When this happens, release the P3 button and the following procedures will be carried out automatically.



- 5) **Search for closed gate position** The board automatically searches for the “closed gate” position; the doors are moved in the closing direction until they hit the mechanical gate-closed stops (if the gate is already closed, the board will still carry on the search, forcing itself against the mechanical gate-closed stops for a few seconds).

PLEASE NOTE THAT IF THE GATES DO NOT COMPLETE THE FULL CLOSE CYCLE AT THIS POINT, (IE, STOP HALFWAY AND OPEN AGAIN). START THE PROGRAMMING AGAIN WITH THE AMP TRIMMER INCREASED TO A HIGHER SETTING. SOME TYPES OF MOTOR WILL NEED A HIGHER AMP SETTING INITIALLY TO FULLY COMPLETE THE CYCLE.

- 6) **Search for open gate position.** The board automatically searches for the “open gate” position; the gate for motor 1 opens and after 3 seconds (fixed or preset delay) the gate for motor 2 starts to open. In order to protect the mechanical parts, the gates start to open slowly and then continue to open at the normal working speed. The gates reach the mechanical stops for the open gate position at the normal moving speed (without slowing down). The motors stop automatically after recognizing the position of the two gates. The stroke is calculated and the deceleration points are recorded.
- 7) **Gate closes** The gate automatically carries out the closing cycle. The gate starts to move slowly and then carries on to the normal speed. A fixed delay of 3 seconds is inserted before the second gate starts to move.
Deceleration of the closing gate. The gate finishes closing with the slowing down period (calculated during previous opening phase), and stops correctly on the mechanical stops.
End of auto-calibration cycle. The gate is completely closed and the board exits from automatic-programming function (LED DL6 turns off)

The gates can now be operated via the remote controls and the same sequence just recorded should operate every time. Fine tuning of the trimmers can now be adjusted to obtain the correct amount of overall speed, slowdown speed and obstacle detection by adjusting the trimmers. **If the VELOC or RALL trimmers are adjusted to control and correct speeds, it may be necessary to carry out the self or manual programming again once the correct speeds are obtained.**

In particular check that the gates detect obstacles with a minimum effort controlled by the **AMP** trimmer.

OBSERVE THE APPLICABLE PARTS OF STANDARDS EN 13241-1, EN 12453, EN 12445 TO FULLY COMPLY.

The **AMP** trimmer controls the current absorbed by the motor before the obstacle detection reverses or stops the motor.

The **RALL** trimmer controls the speed of the motor during the slowdown period.

The **VELOC** trimmer controls the speed of the motor during the normal run period.

If the **VELOC** trimmer is reduced to control the normal run speed, the **RALL** speed (slowdown period) will also reduce, so the **RALL** trimmer will need to be increased proportionally by the same amount to maintain the same slow period speed

Check the operation of the photocells! The gate should stop and reopen, when you break the photocell beam during the closing cycle of the gate.

Manual programming of working times and slowing speed

The manual programming procedure enables the installer to fine tune the work and slowing times of the gate wings

The following describes the programming stages for the two gates; in the event of single gate (DIP1 SW1 = ON), only the stages related to motor M1 are carried out.



Make sure that you have end stops for each wing set. Depending on the motor type, these may be built into the motor or for motors without stops a gate wing stop will be needed. A closing floor stop, (CENTRE STOP) is highly recommended in any case because this ensures that the gates are held tight when closed. The gates will not programme or run without any stops, it needs them to figure out its positions.

You need to verify that the motors are going in the right direction in relation to the panel. Arrange gate's so that they are both approximately half way. Turn the power off to the panel. **(It is important that you leave the power off to the panel at least 15 seconds or the fuse may fail when you turn back on the power)** Turn the power back on again. Press once the key fob that you previously learned in at step 2 and 3. Observe the direction that both gates move in at the start and then immediately turn the power off again. The gate if that travels in an open direction is correct. The gate that travels in a closing direction is incorrect. Identify this motor at the PCB as M1 or M2 and these motor wires need swapping with each other.



- 1) Position the gate/s at fully closed and make sure the motors are locked into drive. You can check this by pulling or pushing the gate slightly, if the motor was previously unlocked, the motor will click and the gate wing will lock.
- 2) Arrange the trimmers to an initial setting point. With 24V motors, set the AMP and RALL trimmers to 11 O'clock. With 12V motors, set the AMP and RALL trimmers to 12 O'clock. Set the VELOC trimmer to full for all motors.

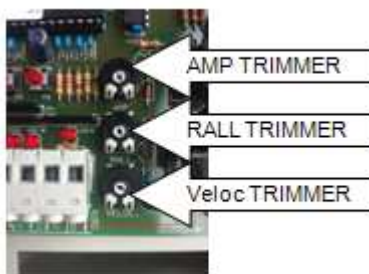

- 3) **Entering manual programming** With the gates closed, press and release once on P3, (LEARN) DL6 will start to flash.



- 4) **Start opening: start first door (motor 1)**.. Press and release the P2, (WORK) key. The door for motor 1 starts opening, initially slowly and then to normal speed.



- 5) **Deceleration in opening for first door (motor 1)**. When the door for motor 1 reaches the desired deceleration point, press and release the P2 (WORK) key, the door of motor 1 will slow down.
- 6) **Completing opening of the first door (motor 1)**. When the door for motor 1 reaches the end of its stroke (door open position stop), the threshold of current sensor triggers and the motor stops automatically.

- 7) **Starting delay in opening between gate 1&2.** Press once P2 (WORK) the delay calibration in opening will start. LED DL6 flashes at a high frequency.
- 8) **End of delay in opening, the second door starts opening (motor 2).** After the desired phase of delay, press once the P2 (WORK) (the time between the two pressing of WORK will determine the phase displacement interval for opening. The door for motor 2 starts to open: the LED flashes normally.
- 9) **Deceleration in opening for second door (motor 2).** When the door for motor 2 reaches the desired deceleration point, press and release the P2 (WORK) key, the door for motor 2 will slow down.
- 10) **Completing opening of the second door (motor 2).** When the door for motor 2 reaches the end of its stroke (door open position), the threshold of current sensor triggers and the motor stops automatically. LED DL6 stays on.
- 11) **Starting closing: start second door (motor 2).** Press and release the P2 (WORK). The door for motor 2 starts to close, initially slowly and then accelerating to normal speed.
- 12) **Deceleration of closing for second door (motor 2).** When the door for motor 2 reaches the desired deceleration point, press and release the P2 (WORK) the door for motor 2 will slow down.
- 13) **Completing closure of the second door (motor 2).** When the door for motor 2 reaches the end of its stroke (door closed position), the threshold of current sensor triggers and the motor stops automatically.
- 14) **Starting the phase displacement interval for closing.** Press and release the P2 (WORK) the timing of the displacement interval for closing will start. (the overlap time between gate 1&2 closing so that both gates do not close at once) The LED DL6 will start to flash at a high frequency.
- 15) **End of displacement interval for closing, the first door starts closing (motor 1).** After the desired phase displacement interval for closing, press and release the P2 (WORK) the time between pressing WORK will determine the phase displacement interval for closing. The door for motor 1 starts to close: the LED flashes normally.
- 16) **Deceleration of closing for first door (motor 1).** When the door for motor 1 reaches the desired deceleration point, press and release the P2 (WORK) the door for motor 1 will slow down.
- 17) **Completing closure of the first door (motor 1).** When the door for motor 1 reaches the end of its stroke (door closed position), the current control triggers and the motor stops automatically. The gate is closed and the complete working cycle has been programmed (opening and closing); the board automatically exits from programming and LED DL6 turns off.

The gates can now be operated via the remote controls and the same sequence just recorded should operate every time. Fine tuning of the trimmers can now be adjusted to obtain the correct amount of overall speed, slowdown speed and obstacle detection by adjusting the trimmers. **If the VELOC or RALL trimmers are adjusted to control and correct speeds, it may be necessary to carry out the self or manual programming again once the correct speeds are obtained.**

In particular check that the gates detect obstacles with a minimum effort controlled by the **AMP** trimmer.

OBSERVE THE APPLICABLE PARTS OF STANDARDS EN 13241-1, EN 12453, EN 12445 TO FULLY COMPLY.

The **AMP** trimmer controls the current absorbed by the motor before the obstacle detection reverses or stops the motor.

The **RALL** trimmer controls the speed of the motor during the slowdown period.

The **VELOC** trimmer controls the speed of the motor during the normal run period.

If the **VELOC** trimmer is reduced to control the normal run speed, the **RALL** speed (slowdown period) will also reduce, so the **RALL** trimmer will need to be increased proportionally by the same amount to maintain the same slow period speed.

Check the operation of the photocells! The gate should stop and reopen, when you break the photocell beam during the closing cycle of the gate.

Programming automation closing

Before you change the gate/s to automatic closing, consider that the gates will be operating unattended and could close while a vehicle is within the swing area of the gates. Adding another set of photocells to the system as pictured on page 6 and wire in as page 5 wiring to prevent this situation.

(Make sure the gates are closed first)

1) Enter manual programming. Press and release the P3 button (**LEARN**) The LED DL6 will start to flash.

2) **Start timing pause length.** Press and release the P1 (**BREAK**) button. The timing of pause length starts (automatic re-closing time); led DL6 and the warning lamp start to flash at high frequency.

End timing pause length. Press and release the P1 (**BREAK**) button; timing of pause length ends (automatic reclosing time). The board automatically exits from manual programming (LED DL6 and the warning lamp turn off) and sets the time for automatic closing between the two pressures of P1 (**BREAK**) key.

DELETING AUTOMATIC CLOSING

1) Enter manual programming. Press and release the P3 button (**LEARN**) button. The LED DL6 will start to flash.

2) Deleting automatic closing time Press and release the P1 (**BREAK**) button twice. This sets the automatic closing waiting time to zero. LED DL6 turns off.

PROGRAMMING RADIO CODE (START CONTROL)

1) Enter radio code programming (for the START control). Press and release the P3 button (**LEARN**) button. The LED DL6 will start to flash.

Use the transmitter to send the radio code to be stored and associated with the START control. The board accepts the code and exits from programming (DL6 turns off). It is possible to store up to a maximum of 32 different codes for the START control.

PROGRAMMING RADIO CODEP (PEDESTRIAN CONTROL)

1) Enter radio code programming (for the PEDESTRIAN control). P3 button (**LEARN**) button twice; LED DL6 will start to flash quickly.

Use the transmitter to send the radio code to be stored and associated with the PEDESTRIAN control. The board accepts the code and exits programming (DL6 turns off). It is possible to store up to a maximum of 32 different codes for the PEDESTRIAN control.

DELETING RADIO CODES: Press the P3 button (**LEARN**) button and the P1 (**BREAK**) button **simultaneously** (LED DL6 will flash at a high frequency); keep them pressed for at least 10 seconds (until LED DL6 goes off), all the stored radio codes (associated with both START and PEDESTRIAN) will be deleted.

Programming additional equipment for the 207C circuit board

LEB Radio-keypad programming

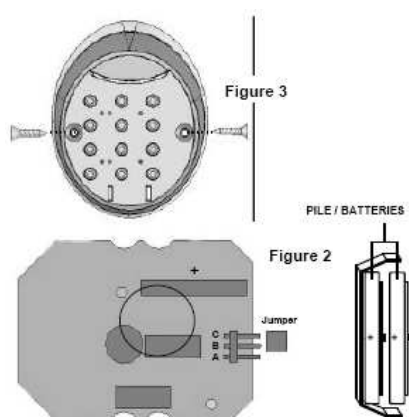

www.theelectricgateshop.co.uk/Product-1278/

SILICONE SEAL AROUND SCREW HOLES AFTER INSTALL



Drill a small weep hole here to let out any moisture.

1. Move the jumper shown in Fig. 2 to A.B from B.C. This will activate the unit
2. Install the keypad in location. Do not overtighten the screws. Overtightening can distort the pad and leave the keys inoperative
3. Dial in the following numbers to set the keypad to standard 20 mode. Dial in the numbers exactly as quoted here and ignore that the unit does not bleep every time a button is pressed during this procedure.
4. Dial in, **00000 OK 99999 OK 5**
5. Enter radio code programming (for the START control). On the 207C panel, press and release the P3 button (**PROGR**) button. The LED DL6 will start to flash. Dial in the numbers of your choice, (max5) and end with OK. The DL6 will go out. Dial in the same numbers again and end with OK, the gates should open.
6. Enter radio code programming (for the PEDESTRIAN control). P3 button (**PROGR**) button twice; LED DL6 will start to flash quickly. Dial in the numbers of your choice, (max5) and end with OK. The DL6 will go out. Dial in the same numbers again and end with OK, the pedestrian gate should open.

ELBE Wireless Radio-Keypad Programming

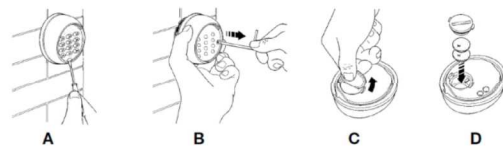
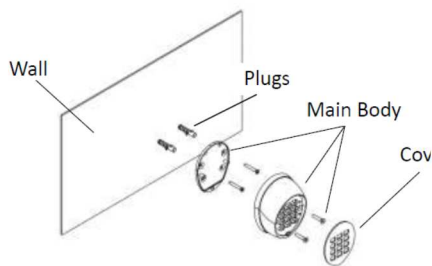

Audible Signal	Status
1 short beep	Keypad tone
1 long beep	Auto power-off
3 long beeps	Modification of combination confirmed
5 short beeps	Error during combination input or combination edit operation
10 rapid beeps	Low battery warning signal - new batteries are required

Installation

Before physically installing the unit in its mounting position it is good practice to perform a practical test to assess the functionality and effective range. Please bear in mind that range may be up to 25 or 30% less when battery power is low.

Positioning

Apart from the distance from the receiver, the units should not be positioned in the vicinity of or - worse still - in contact with metal structures, which could otherwise exert a signal shielding effect. Thanks to the enclosure protection rating of IP 54, the digital selectors can be installed outdoors if required.

A: Changing the combination associated with channel 1 ◀ - Example:

This function allows you to change the combination associated with channel 1 ◀

1. Press the "0" key and hold it down while pressing and releasing 0 ◀
2. Release the "0"key
3. Type in the current number (original factory is,11) combination and press 11◀
4. Type in the new combination (up to 8 digits) and press ◀ (e x a m p l e) 12345 ◀
5. Type in the new combination again 12345 ◀
6. To enter the code for the START control,. With the gate closed locate the P3 LEARN button and push the button once.
7. While DL6 is flashing, dial in the new combination generated at step 4&5, (12345) followed by the ◀symbol.



B: changing the combination associated with channel 2 ▶ - Example:

This function allows you to change the combination associated with channel 2 ▶

1. Press the "0" key and hold it down while pressing and releasing 0 ▶
2. Release the "0" key ▶
3. Type in the current (original) combination and press 22 ▶
4. Type in the new combination (up to 8 digits) and press ▶ (e x a m p l e) 23456 ▶
5. Type in the new combination again 23456 ▶
6. To enter the code for the PEDESTRIAN. With the gate closed press P3 button (PROGR) button twice; LED DL6 will start to flash quickly.
7. While DL6 is flashing, dial in the new combination generated at step 4&5, (23456) followed by the ▶symbol.

Factory reset of the keypad if the current code is lost/not known.

Dis-assemble the keypad and locate the hidden button inside the unit. Press and hold the button down for 10 seconds, the unit will emit a long beep. Re-assemble the keypad and proceed to reprogram as per the beginning of this instruction.

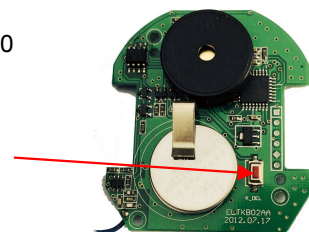

Installer:
 (Name, address, telephone)

UNAC GUIDE No. 2 FOR THE MOTORISATION OF HINGED GATES IN ACCORDANCE WITH MACHINERY DIRECTIVE 98/37/EEC AND THE APPLICABLE PARTS OF STANDARDS EN 13241-1, EN 12453, EN 12445

With this publication UNAC sets out to inform and assist installers in applying the specifications of the directives and of European standards concerning the safe use of motorised gates/doors.

It should be noted that those who sell and *motorise* an existing manual door/gate become the manufacturer of the motorised door/gate *machine* and must prepare and keep the technical file, as laid down by Annex V of the Machinery Directive (98/37/EEC). The technical file must contain the following documents:

- Assembly drawing of the motorised door/gate (usually included in the installation manual).
- Electrical connections and control circuit diagrams (usually included in the installation manual).
- Risk analysis including (as indicated on the following pages):
 - the list of the essential requirements as indicated in Annex I of the Machinery Directive;
 - the list of the risks presented by the door/gate and the description of the solutions adopted.
- They must also keep the manuals for installation and maintenance of the door/gate and of the components.
- Prepare the operating instructions and general warnings for safety (if necessary integrating those in the manual for installation of the door/gate) and give the user a copy.
- Compile the proof book and give the user a copy (see facsimile in Annex 1).
- Draft the EC declaration of conformity (see facsimile in Annex 2) and give the user a copy.
- Fill in the label or plate with CE marking and attach it to the motorised door/gate.

N.B. The technical file must be held and made available to the competent national authorities for at least ten years from the date of construction of the motorised door/gate.

Note also that, as from May 2005, the manufacturer of a new door/gate (both manual and motorised) must observe the procedure for the CE marking pursuant to the Construction Products Directive (89/106/EEC), as indicated in annex ZA of the standard EN 13241-1. This procedure involves the manufacturer:

- setting up and maintaining internal production control;
- having a notified body carry out the initial type tests referring to the applicable characteristics indicated in Annex ZA of standard EN 13241-1.

N.B. UNAC is preparing guidelines dedicated to the correct application of the Construction Products Directive (89/106/EEC).

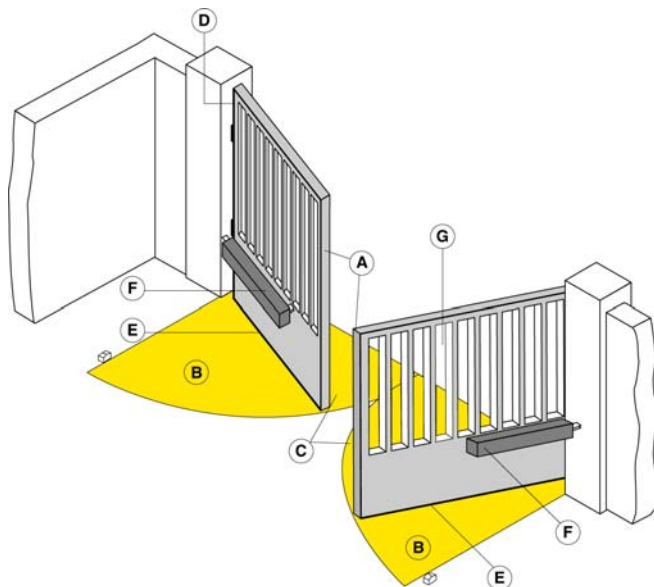

**Risk areas
 of the hinged gate (Figure 1)**

The information given was drafted and checked with the utmost care, nevertheless UNAC declines all responsibility for any errors, omissions or inaccuracies due to technical or graphical requirements. UNAC points out that this guide does not replace the content of standards which the manufacturer of the motorised door/gate must observe.

KEY TO THE MECHANICAL RISKS CAUSED BY MOVEMENT

Pursuant to the Machinery Directive:

- “Danger zones” refer to any zone within and/or around machinery in which an exposed person is subject to a risk to his or her health and safety.
- “Exposed person” refers to any person wholly or partially in a danger zone.

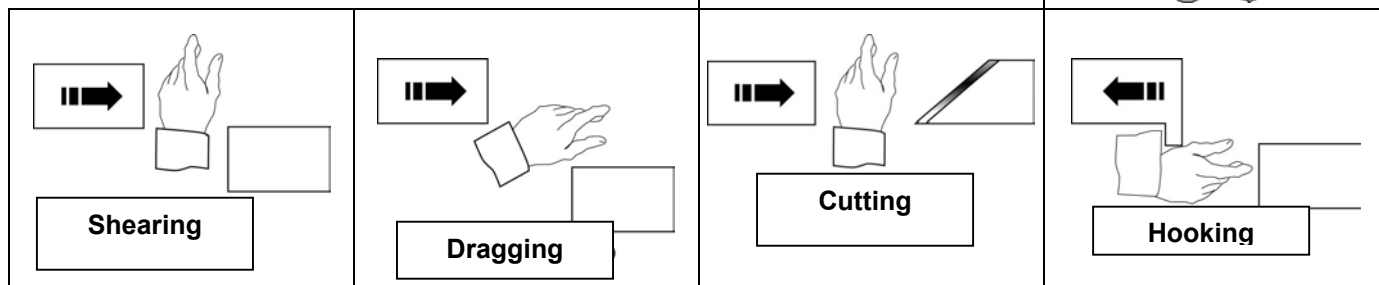
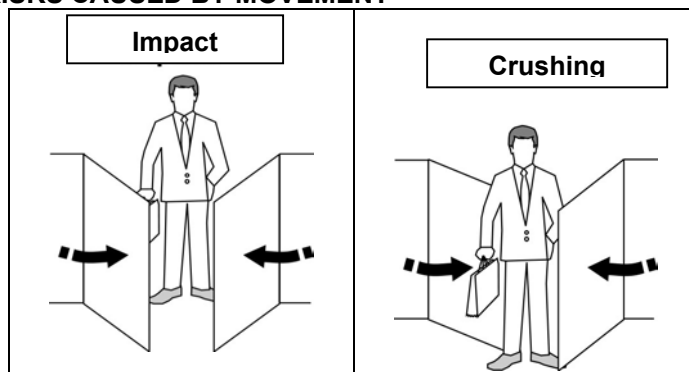

MINIMUM LEVEL OF PROTECTION OF THE MAIN EDGE

Type of actuation controls	Type of use		
	Informed users (private area)	Informed users (public area)	Uninformed users
Hold-to-run control	Pushbutton control	Pushbutton control with key	Hold-to-run control not possible
Impulse control with door visible	Limitation of forces, or presence sensing devices	Limitation of forces, or presence sensing devices	Limitation of forces and photocells, or presence sensing devices
Impulse control with door not visible	Limitation of forces, or presence sensing devices	Limitation of forces and photocells, or presence sensing devices	Limitation of forces and photocells, or presence sensing devices
Automatic control (e.g. timed closure control)	Limitation of forces and photocells, or presence sensing devices	Limitation of forces and photocells, or presence sensing devices	Limitation of forces and photocells, or presence sensing devices

ANALYSIS OF THE RISKS AND CHOICE OF SOLUTIONS

IN ACCORDANCE WITH THE MACHINERY DIRECTIVE 98/37/EEC AND THE STANDARDS EN 13241-1, EN 12453, EN 12445

The risks listed below follow the sequence of the installation process. These risks are those which are commonly present in motorised doors/gates systems. According to the various situations, consideration therefore has to be made of any possible additional risks and exclude those which are not applicable. The solutions to be adopted are those indicated by the standards mentioned above; in the case of risks not dealt with, the safety integration principles indicated by the Machinery Directive (Annex 1 – 1.1.2) have to be applied.

MD Ann. 1	Type of risks	Evaluation criteria and solutions to be adopted (Tick the box corresponding to the solution adopted)
1.3.1 1.3.2	<i>Mechanical, structural and wear risks.</i> [1] Loss of stability and break-up.	<input type="checkbox"/> Check the solidity of the structure installed (jambs, hinges and leaves) in relation to the forces generated by the motor. Attach the motor stably using adequate materials. If available, check the content of the EC declaration of conformity of the manual gate. <input type="checkbox"/> If necessary, carry out the structural calculation and attach it to the Technical File. <input type="checkbox"/> Check that the travel of the leaves is limited (during opening and closure) by mechanical stops of adequate strength. Check that the leaves cannot, under any circumstance, exit their slide guides and fall.
1.5.15	[2] Tripping.	<input type="checkbox"/> Check that any thresholds higher than 5 mm are visible, indicated or shaped.

MD Ann. 1	Type of risks	Evaluation criteria and solutions to be adopted (Tick the box corresponding to the solution adopted)
1.3.7 1.3.8 1.4	<p>Mechanical risks caused by the movement of the gate (see references in Figure 1).</p> <p><input type="checkbox"/> CAUTION – If the door/gate is used solely with hold-to-run controls (and meets the requirements of the standard EN 12453), the danger points listed below do not have to be protected.</p> <p><input type="checkbox"/> CAUTION – If protective devices are installed (in accordance with the standard EN 12978) which prevent in all cases contact between the moving leaf and persons (for example photoelectric barriers, presence sensing devices), it is not necessary to measure the operating forces.</p>	

[3] Impact and crushing on the main closing edge (Figure 1, risk A).

Measure the closure forces (by means of the special instrument required by the standard EN 12445) as illustrated.

In the case of gates with two leaves, the closure force should be measured one leaf at a time.

Check that the values measured by the instrument are below those indicated in the graph.

Carry out the measurements in the following points:
 L = 50, 300 and 500 mm;
 H = 50 mm,
 at mid-height of the leaf and
 at the height of the leaf minus 300 mm (max 2500).

N.B. The measurement should be repeated three times in each point and the average value considered.

The graph indicates the maximum values of the dynamic, static and residual operating forces in relation to the various positions of the leaf.

N. B. With reference to the measurement points with L = 50, 300 and 500 mm, the maximum dynamic force value permitted is 400 N.

If the values of the forces are higher, install a protective device in accordance with the standard EN 12978 (for example a sensitive edge) and repeat the measurement.

N. B. The dynamic force can be reduced, for example, by reducing the speed of the leaf or using a sensitive edge with high elastic deformation.

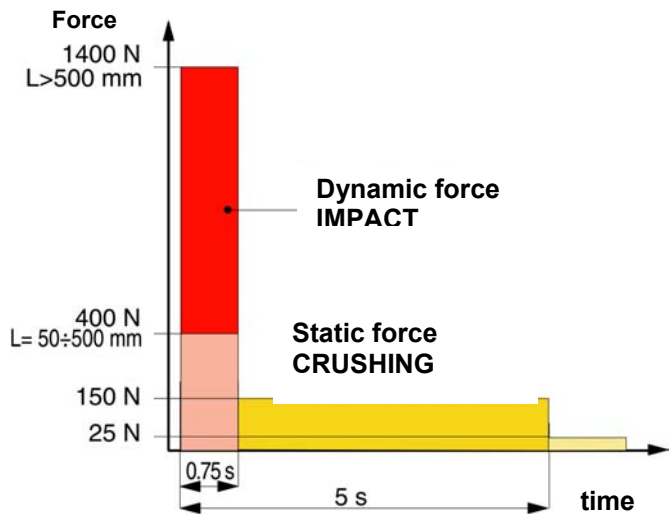
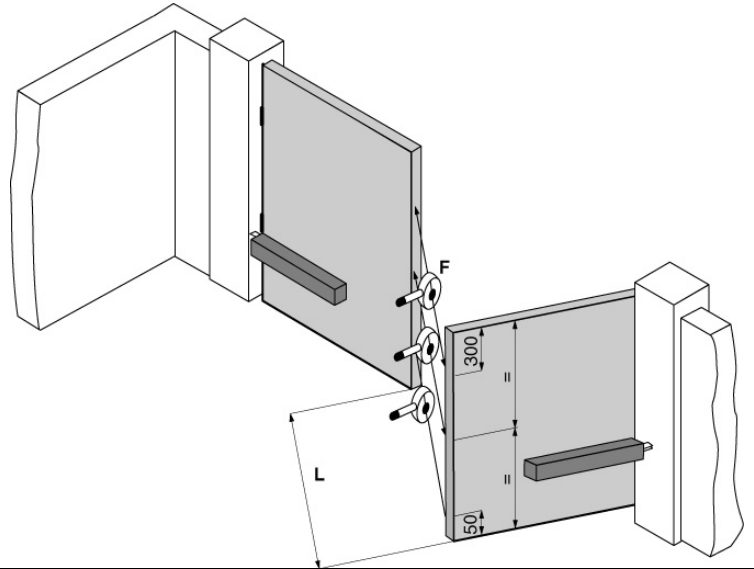

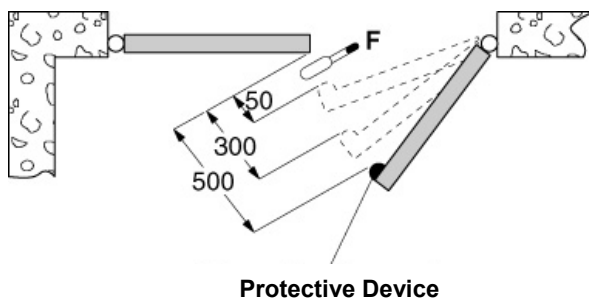

Leaves with overlapping and delayed closure

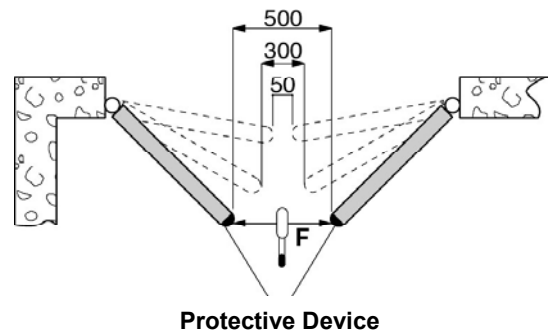

Leaves with simultaneous closure

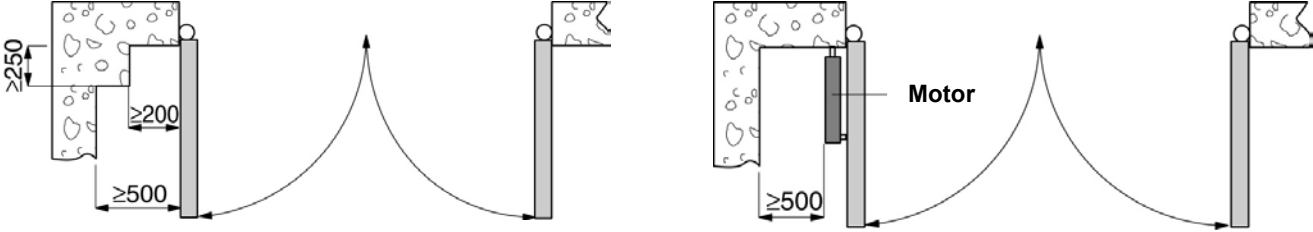
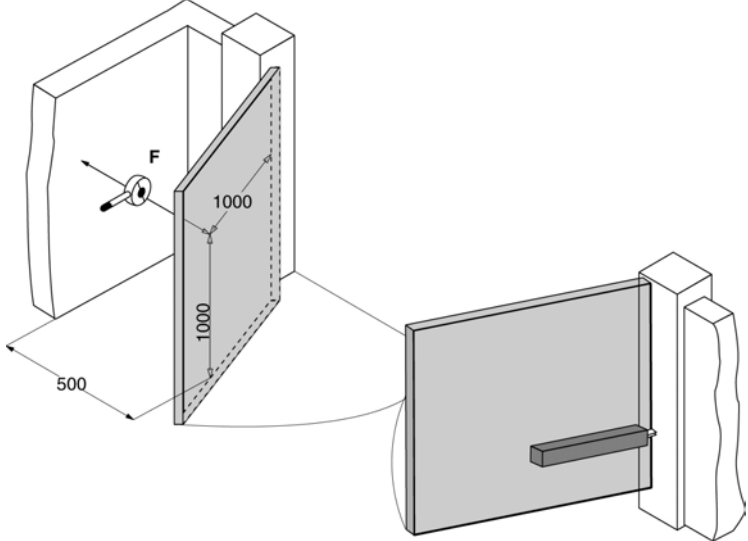
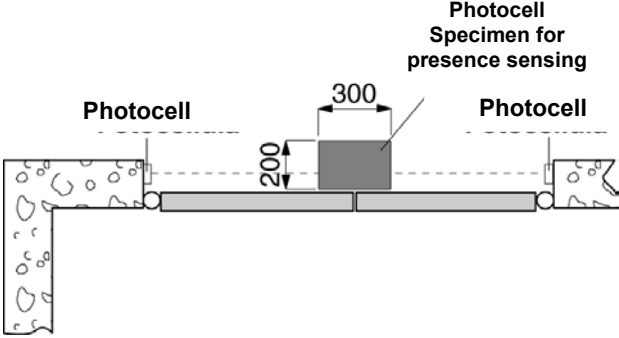
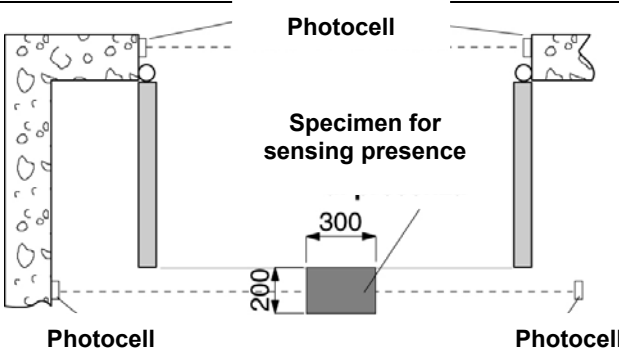

MD Ann. 1	Type of risks considered	Evaluation criteria and solutions to be adopted (Tick the box corresponding to the solution adopted)
<p>[4] Impact and crushing in the area of opening (Figure 1, risk B).</p> <p><input type="checkbox"/> Observe the safety distances illustrated (in the most prominent part of the leaf).</p> 		
<p>or:</p> <p><input type="checkbox"/> Measure the forces of opening (by means of the special instrument required by the standard EN 12445) as illustrated. Check that the values measured by the instrument are less than those indicated in the graph above.</p> <p>Carry out the measurement at a height of 1000 mm (or in the most prominent point of the leaf)</p> <p><i>N.B. The measurement should be repeated three times and the average value considered.</i></p> <p><input type="checkbox"/> If the values of the forces are higher, install a protective device in accordance with the standard EN 12978 (for example a sensitive edge) and repeat the measurement.</p> 		
<p>[5] Impact in the area of closure (Figure 1, risk C).</p> <p><input type="checkbox"/> Install a pair of photocells (recommended height 500 mm) so as to sense the presence of the test parallelepiped (height 700 mm) positioned as illustrated.</p> <p><i>N.B. The test specimen for presence sensing is a parallelepiped (700 x 300 x 200 mm) with 3 faces with a light and reflective surface and 3 faces with a dark and opaque surface.</i></p> 		
<p>[6] Impact in the area of opening (Figure 1, risk B) and in the area of closure (Figure 1, risk C)</p> <p><input type="checkbox"/> To reduce further the possibility of impact in the areas of movement of the gate, it is possible to install a pair of photocells (recommended height 500 mm) so as to sense the presence of the test parallelepiped (height 700 mm) positioned as illustrated.</p> 		

MD Ann. 1	Type of risks	Evaluation criteria and solutions to be adopted (Tick the box corresponding to the solution adopted)
1.3.7 1.3.8 1.4	<p><i>Mechanical risks due to movement of the leaf.</i></p> <p>[7] Dragging of the hands on the hinges side edge (Figure 1, risk D).</p> <p>[8] Dragging of the feet on the lower edge (Figure 1, risk E).</p> <p>[9] Dragging of the hands on the drive unit (Figure 1, risk F).</p> <p>[10] Dragging, hooking and cutting due to the shaping of the mobile leaf (Figure 1, risk G).</p>	<p><input type="checkbox"/> Check that there is a clearance ≥ 25 mm,</p> <p>or:</p> <p><input type="checkbox"/> attach guards that prevent fingers from being inserted (for example a rubber strip).</p> <p><input type="checkbox"/> The clearance between the gate and ground must prevent the risk of dragging of the feet.</p> <p><i>N.B. Should, due to the slope of the ground, the clearance vary, guards should be attached (e.g. rubber strips).</i></p> <p><input type="checkbox"/> If the distances between the drive unit and the leaf vary, check on the presence of a clearance ≥ 25 mm, or attach guards (e.g. covers or strips in rubber).</p> <p><input type="checkbox"/> Eliminate or protect any sharp edges, handles, projecting parts etc. (for example by means of covers or strips in rubber).</p>
1.5.1 1.5.2 1.5.10 1.5.11	<p><i>Electrical and electromagnetic compatibility risks</i></p> <p>[11] Direct and indirect contacts. Dispersion of electrical energy.</p> <p>[12] Risks relating to electromagnetic compatibility.</p>	<p></p> <p><input type="checkbox"/> Use CE-marked components and materials pursuant to the Low Voltage Directive (73/23/EEC).</p> <p><input type="checkbox"/> Carry out the electrical connections, connection to the mains, earth connections and relevant checks, in accordance with current regulations and as indicated in the installation manual of the drive unit.</p> <p><i>N.B. If the electrical supply line is already set up (via both a socket and a connector block), declarations of conformity to Italian law no. 46/90 are not necessary.</i></p> <p><input type="checkbox"/> Use CE-marked components pursuant to the EMC Directive (89/336/EEC). Carry out the installation as indicated in the manual for installation of the drive unit.</p>
1.2 1.5.3 1.2.3 1.2.4	<p><i>Safety and reliability of drive unit and control and safety devices.</i></p> <p>[13] Safety conditions in the event of malfunctioning and power failure.</p> <p>[14] Energy types other than electrical energy</p> <p>[15] Actuation and disabling of the drive unit.</p> <p>[16] Power supply switch.</p>	<p><input type="checkbox"/> Use drive units which comply with the standard EN 12453 and safety devices which comply with the standard EN 12978.</p> <p><input type="checkbox"/> If hydraulic drive units are used, they must comply with the standard EN 982; or</p> <p><input type="checkbox"/> if pneumatic drive units are used, they must comply with the standard EN 983.</p> <p><input type="checkbox"/> Check that, after a fault or power failure, the drive unit restarts safely without creating hazardous situations.</p> <p><input type="checkbox"/> Install an omnipolar switch for electrical insulation of the door/gate, in accordance with current laws. This switch must be positioned and protected against accidental or unauthorised actuation.</p>

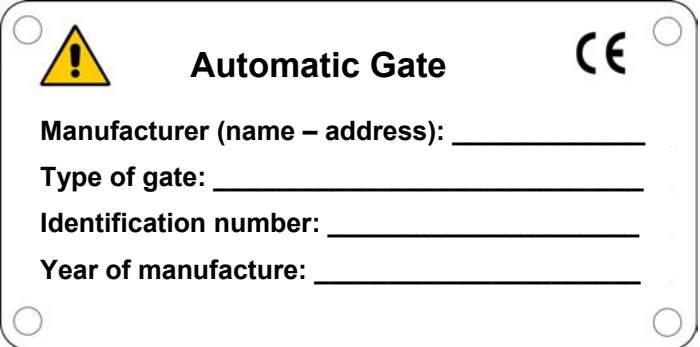
MD Ann. 1	Type of risks	Evaluation criteria and solutions to be adopted (Tick the box corresponding to the solution adopted)
1.2.5	[17] Consistency of controls	<input type="checkbox"/> Install the controls (e.g. key selector) so that the user is not in a danger zone, and check that the meaning of the controls has been understood by the user (for example the function selector). <input type="checkbox"/> Use CE-marked radio controls pursuant to the R&TTE directive (1999/5/EEC) and complying with the frequencies admitted by the laws of each individual country.
1.5.14	[18] Risk of trapping.	<input type="checkbox"/> Install a device for release of the drive unit that allows manual opening and closure of the leaf with force no higher than 225 N (for doors/gates in residential areas) or 390 N (for doors/gates in industrial or commercial areas). Supply the user with the means and instructions for the release operations. Check that operation of the release device is simple and does not create additional risks.
1.2.4	[19] Emergency stop.	<input type="checkbox"/> If appropriate, install an emergency stop control in accordance with the standard EN 418. <i>N.B. Make sure that the emergency stop does not introduce additional risks, aborting operation of the safety devices installed.</i>
1.7.1 1.7.2 1.7.3 1.7.4 1.6.1 1.1.2	<i>Integration principles for safety and information.</i> [20] Signalling equipment. [21] Warnings. [22] Marking. [23] Operating instructions. [23] Maintenance. [24] Unprotected residual risks.	<input type="checkbox"/> A flashing light should be installed, in a visible position, to indicate movement of the leaf. <input type="checkbox"/> Traffic lights can be installed to control vehicle traffic. <input type="checkbox"/> Reflectors can also be attached to the leaf. <input type="checkbox"/> Attach all those signs or warnings considered necessary for indicating any unprotected residual risks and to indicate any foreseeable improper use. <input type="checkbox"/> Attach the label or plate with the CE marking and containing at least what is shown in the illustration. <div data-bbox="715 1308 1417 1653" style="border: 1px solid black; padding: 10px; margin: 10px auto; width: fit-content;">  </div> <input type="checkbox"/> Consign to the user the operating instructions, safety warnings and EC declaration of conformity (cf. facsimile in Annex 2). <input type="checkbox"/> A maintenance plan has to be drawn up and implemented. Check on the proper working of the safety devices at least every 6 months. <input type="checkbox"/> Record the work carried out in the proof book in accordance with the standard EN 12635 (cf. facsimile in Annex 1). <input type="checkbox"/> Inform the user in writing (for example in the operating instructions) of any unprotected residual risks and foreseeable improper use.